

PCIe Gen2 Expansion System



The Adnaco-S1B PCI Express Gen2 Expansion System allows system integrators to operate 4 PCIe add-in cards over fiber optic cable at distances up to 250 meters from the location of the computer system. No additional host software drivers are required during installation or operation. Any type of PCI Express cards can be used including audio, video, graphics, USB, FireWire, SATA, data-acquisition, network and others. The system consists of a PCIe host adapter, a fiber optic cable and an expansion chassis.

Product Features:

- Host adapter can be installed into any PCIe slot
- 2.5 Gb/s or 5 Gb/s PCIe communication
- 4 PCIe add-in cards can operate simultaneously in expansion chassis
- Auto power on/off
- Compact thermally advantaged chassis
- 300W power supply, SFX12V 3.0 complaint, active PFC, universal input
- Host processor and OS independent
- Optical isolation
- Cable length up to 250 meters
- SFP transceivers with LC connectors

Specifications: Adnaco-S2B PCIe Gen2 Expansion System

| | |
|-------------------|--|
| Product Name | Adnaco-S2B |
| Host card | Adnaco-H1A |
| Expansion chassis | Adnaco-C2B |
| Fiber optic cable | LC-LC, Multi-mode, Duplex, 50/125 μ m, 10 m or 50 m |
| Communication | One full duplex 2.5 Gb/s or 5.0 Gb/s link over fiber optic cable |
| Software | Transparent to software applications and drivers |

Expansion Chassis Specifications

| | |
|-----------------------|---|
| Product Name | Adnaco-C2B |
| Backplane | Adnaco-R1BP1B Four 2.5 Gb/s or 5.0 Gb/s PCIe x16 (electrical x1) connectors |
| Physical Dimensions | 136 mm W x 370 mm D x 329 mm H (5.3"W x 14.5"D x 12.9"H) |
| Material | Steel chassis, flame retardant plastic parts |
| Drive Bays | 1 - 5.25" CD-ROM 2 - 3.5"(1") HDD |
| System Cooling | One power supply fan Two rear-mount 60mm fans (one optional) |
| Power Supply | SFX12V 3.0 complaint, active PFC, universal input INPUT Input Range 90..264VAC Frequency 47..63Hz Input Current <6A @ 90VAC Efficiency >70% @ 115/230VAC OUTPUT Maximum Power 300W +3.3 V 18.0 A +5.0 V 18.0 A +12.0 V 11.0 A -12.0 V 0.4 A |
| Operating Environment | Temperature: 0° C to +55° C Relative Humidity: 10 to 85%, non-condensing |
| Storage Environment | Temperature: -40° C to +70° C Relative Humidity: 5 to 85%, non-condensing |
| Regulatory Compliance | FCC class B, ICES-003 class B, CE |
| Weight | 6.1 kg (13.4 lb) |

Ordering Information

| Part Number | Contents |
|------------------|--|
| Adnaco-S2B-01-10 | PCIe Gen2 Expansion System with 10 m fiber optic cable Parts: Adnaco-H1A-01, Adnaco-C2B, Adnaco-FC1-01-10 |
| Adnaco-S2B-01-50 | PCIe Gen2 Expansion System with 50 m fiber optic cable Parts: Adnaco-H1A-01, Adnaco-C2B, Adnaco-FC1-01-50 |

Related Documents and Products:

| | |
|-----------------------|--|
| Adnaco-H1A | PCIe Gen2 Host Adapter Data Sheet |
| Adnaco-R1BP1B | Adnaco-R1BP1B PCIe Gen2 Expansion Backplane Data Sheet |
| Adnaco-Sirius-R1TK-UG | PCI Express Extension Over Fiber Optic Test Kit User's Guide |

System Block Diagram

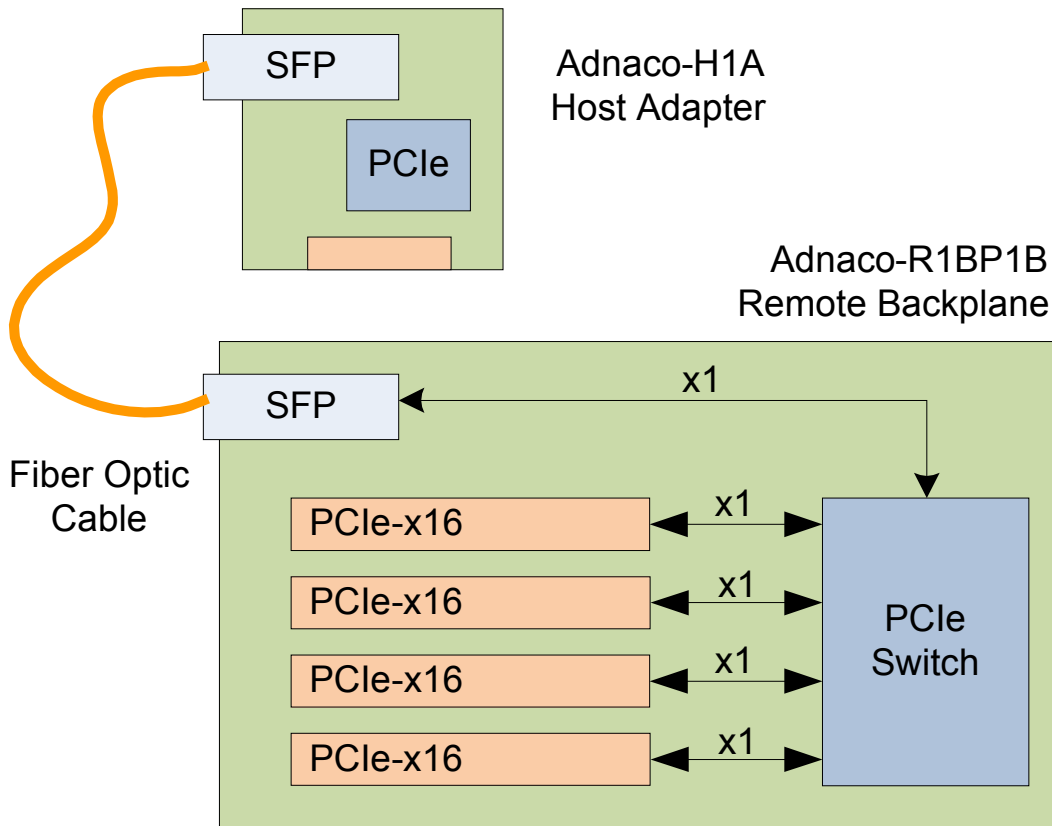

© 2006-2011 Adnaco Technology Inc. All rights reserved. **Adnaco™** is a trademark of Adnaco Technology. Other product and company names listed are trademarks or trade names of their respective companies. Adnaco Technology may make changes to specifications and product descriptions at any time, without notice.